

## Release Fork Service Bulletin



Arrow indicates  
Problem area.

**Problem:** Noisy clutch pedal bounce at bottom of pedal travel, or when clutch brake is being applied

**Answer:** Release for is contracting pressure plate

### Solution

1. Remove fork through inspection hole
2. Replace with new fork. (Note: New fork from IH has radius ground-in fork for more clearance)
3. If a new fork is not readily available, a 3" long and 3/8" deep radius can be ground into the fork for extra clearance
4. Some new release forks are coming out with the radius ground on the wrong side. The radius must be on the clutch side of the fork, not on transmission side

## Mounting Pressure Plate to Flat Flywheel

After flywheel has been ground, two problems can occur:

1. If the centering ring has not been ground, it can prevent the pressure plate from mounting flat to the flywheel
2. After flywheel has been ground, make sure there is not a radius in the corner of flywheel by centering ring. This will keep pressure plate from mounting up flat

### Adjustment Procedure for Spicer Angle-Spring and Angle-Spring 2 Clutches

**IMPORTANT:** Critical checks before making any internal adjustments:

1. Clutch brake "squeeze" (increase resistance) must occur 1" above floorboards. This adjustment is made by shortening or lengthening the external linkage rod (Figure 51)
2. There must be 1-1/2" of free pedal at the top of the stroke. If not, the clutch will slip or burn out (Figure 52). This adjustment is made internally in the clutch – **never with the linkage**
3. There must be 5/8" movement of the clutch release bearing for the clutch to release properly (Figure 53). If these conditions exist, the clutch is properly adjusted. If not, adjustment of the clutch is accomplished by using the adjusting ring (Figure 54).  
Specific instructions for manual and self-adjusting clutches are as follows:

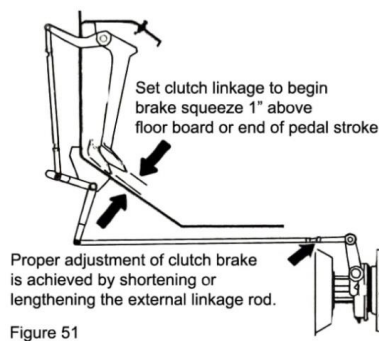

Figure 51

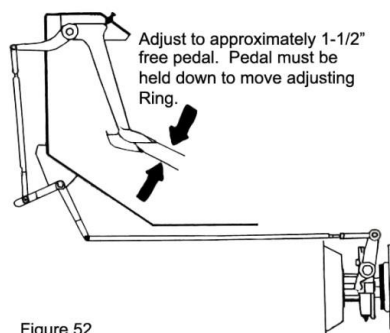

Figure 52

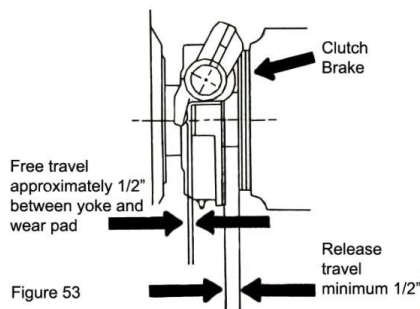

Figure 53

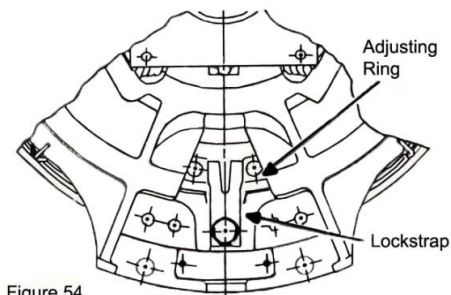
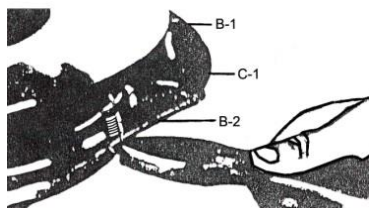

Figure 54

12. See figure 26. Install return springs as shown. Make sure they are completely seated in Hole.



#### Assembly Instructions

##### NOTICE

Due to shipping weight considerations, this spicer PPA has been shipped in two pieces. To assemble, place the cast plate on the back plate with index marks aligned. Install the 4 return springs as indicated in the picture in the four marked locations.