

# Gear Pump Conversion (830456 & 830457)

## Instruction Guide

### DISASSEMBLY INSTRUCTIONS – ILLUSTRATION #1

- **Kit converts from closed hydraulic system to open hydraulic system.**
- It is necessary to remove tractor seat, floor plates, rear and side mounted fuel tanks, and drain Hy-Tran for installation of this kit.
- Items #1 through #15 are to be removed from tractor.
- Item #6 spring must be retained for re-installation.
- Items #11, #12, and #13 are removed as an assembly.
- Item #14- also remove the filter retainer, pump suction tube, retaining ring and seal from the filter cavity in the rear frame.

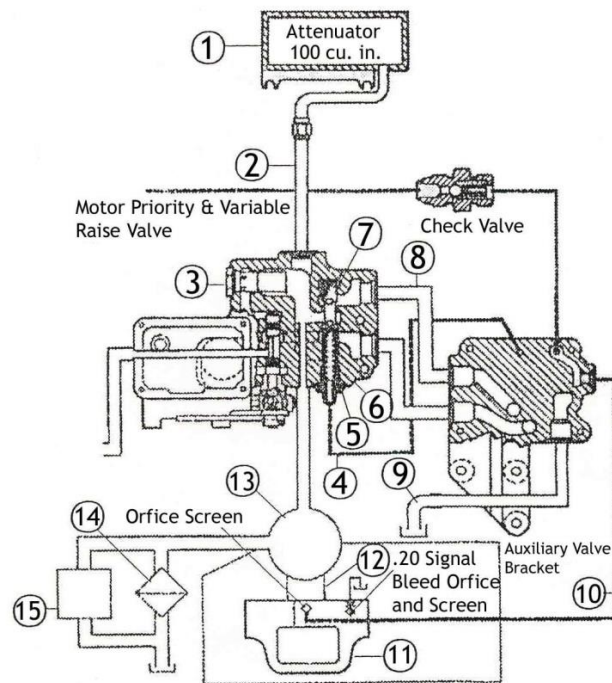

- |                             |                           |
|-----------------------------|---------------------------|
| 1 - Attenuator              | 9 - Elbow                 |
| 2 - Attenuator Line         | 10 - Signal Line          |
| 3 - Pressure Relief         | 11 - Pump Mounting Flange |
| 4 - Signal Line             | 12 - Compensator          |
| 5 - Unloading Valve Fitting | 13 - Piston Pump          |
| 6 - Unloading Valve Spring  | 14 - Filter               |
| 7 - Unloading Valve Spool   | 15 - Filter By-Pass       |
| 8 - Feed Line               |                           |

# Gear Pump Conversion (830456 & 830457)

## Instruction Guide

### ASSEMBLY INSTRUCTIONS – ILLUSTRATION #2 & #3

- Mount pump and spacer to mounting flange, see illustration #2. Loosely attach the pump and flange sub-assembly to the tractor with mounting bolts (not included).
- Install pump suction tube oil seal onto the pump suction tube. The seal lip must face the pump. Reach through the filter cavity and place the suction tube with seal into the housing bore. The suction tube must be fully inserted into the pump suction port. Use a 1-3/16" socket to push the seal into the housing bore.
- Note: DO NOT bottom the seal in the bore as excessive force may lift seal lip. Tighten pump mounting flange bolts.

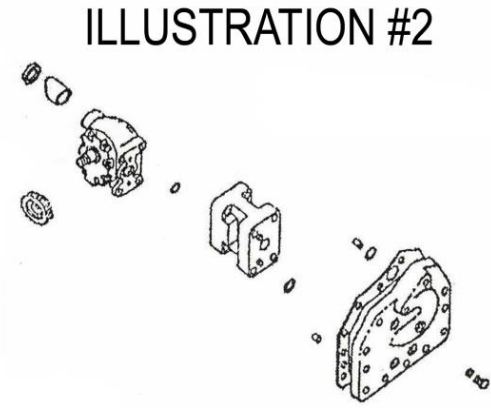

- Install filter retainer. Secure a new hydraulic filter from parts and install it and the new hydraulic filter relief valve in the filter cavity. Install the cover and new unloading valve #7.
- Install the original unloading valve spring #6.
- Install new unloading valve fitting #5.
- Install plug #1 at the port where the signal line was removed from top of the auxiliary valve bracket (see illustration #4).
- Install new tee forward of filter housing with 1/4" NPTF hole pointing up. Install screened orifice #4, see illustration #3.

### ILLUSTRATION #3

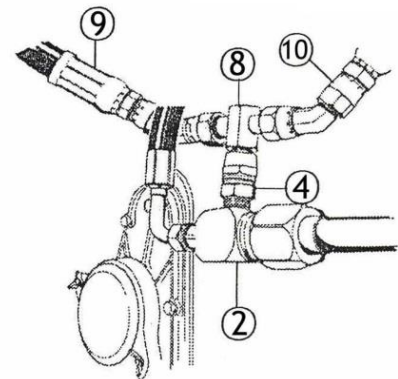

- Install swivel tee #8 to orifice assembly #4.
- Install hose #9 from swivel tee #8, direct hose up to unloading valve fitting #5.
- Install hose #10 from swivel tee #8 to the front of the auxiliary valve bracket.
- Install relief valve #3 (see illustration #4).
- Install hose #11 from the side of motor priority and variable raise valve to the rear of auxiliary valve bracket.
- Install hose #12 from front side of motor priority and variable raise valve to the new tee in front of filter.
- Installation is complete, refill tractor with Hy-Tran.

# Gear Pump Conversion (830456 & 830457)

Instruction Guide

## SCHEMATICS OF THE GEAR PUMP CONVERSION – ILLUSTRATION #4

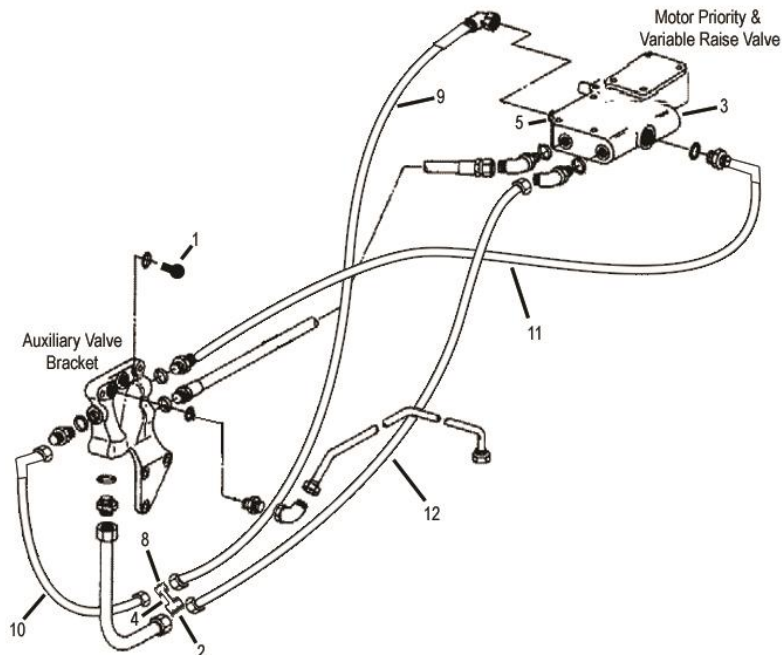
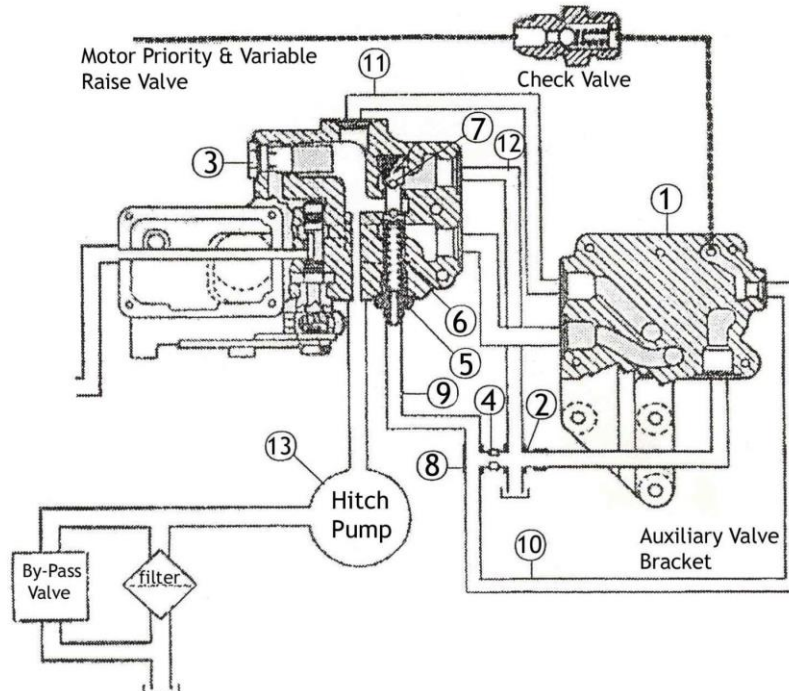

- 1 - Plug, 9/16" Straight Thread w/ O-Ring
- 2 - Tee, 3/4"
- 3 - Pressure Relief
- 4 - Orifice w/ Screen
- 5 - Unloading Valve Fitting
- 6 - Unloading Valve Spring

- 7 - Unloading Valve Spool
- 8 - Tee, 3/8"
- 9 - Hose Assembly, 1/4" I.D.
- 10 - Hose Assembly, 1/4" I.D.
- 11 - Hose Assembly, 5/8" I.D.
- 12 - Hose Assembly, 5/8" I.D.